

Standard Packaged Scintillators

The packaged scintillator is a scintillation crystal mounted in a low-mass metal container (usually aluminum). Reflector material is packed between the scintillator and the container walls, and an optical window is incorporated into one end. A wide variety of shapes (including rectangular) and sizes can be produced. These detectors require user-supplied, externally-coupled photomultiplier tubes.

Packaged scintillators are appropriate for certain experimental or manufacturing situations where different scintillator-PMT combinations may be required on a regular basis.

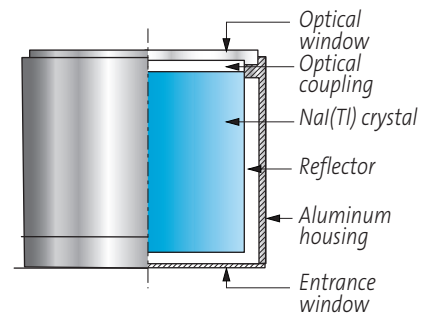

Advantages -

- Reliable, basic, hermetically sealed detector assembly
- Thin aluminum housing (up to .020" thick) with durable, chemically stabilized coating
- Special Bicron K+ window enhances light output
- Stable reflector systems

Options -

- End well and through well geometries
- Low background stainless steel or copper containers
- Thin aluminum or beryllium radiation entrance windows
- Special flanges, O-rings, mounting fixtures or other modifications
- Square, hexagonal and other cross-sections

Other Configurations -

- Ruggedized and high-temperature assemblies
- Assemblies using thin scintillators for low-energy gamma and X-ray detection

Design Notes -

- Detectors made with non-hygroscopic scintillators can be assembled without the optical window, e.g., BGO, CdWO₄.
- Detectors are hermetically sealed when hygroscopic scintillators, e.g., NaI(Tl) are used.
- You can temporarily mount a PMT by using optical coupling compound and black tape to make a light seal. Optical coupling materials are available through your customer service representative. Permanent mounting requires special construction for coupling the PMT and attaching a light shield, which can also be a magnetic shield.

Note: configuration is historically known as:

Bicron Deltaline example model 1R1

Crismatec example model N25X25

Harshaw example model 4D4

Basic Packaged Detectors

Popular Configurations -

Solid detectors are commonly used for simple spectroscopy; general purpose for energies greater than 15 keV.

Typical Solid Crystal Models			
Model	Crystal Size	X-ray Models	Crystal Size
1R1	1" x 1"	1XR.040B	1" x 1mm
1R2	1" x 2"	1.5XR.040B	1.5" x 1mm
1.5R1.5	1.5" x 1.5"	2XR.040B	2" x 1mm
2R2	2" x 2"	B = beryllium window	
3R3	3" x 3"		

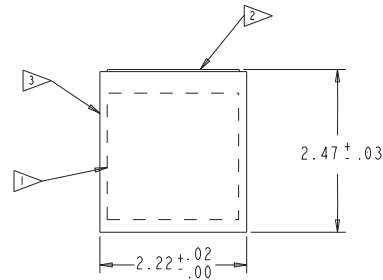

Model 2R2

End well detectors are the most efficient (typically greater than 80%) because the scintillator surrounds the sample; ideal for radioimmunoassay applications.

Typical End Well Crystal Models	
Model	Crystal Size
2RW2	2" x 2"
3RW3	3" x 3"

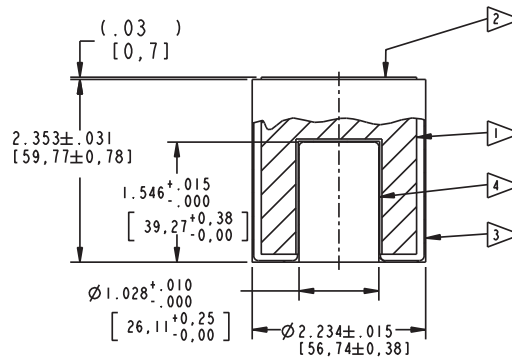

Model 2RW2

Through-side well detectors are ideal when space is limited; they are the second most efficient configuration and are ideal for radioimmunoassay and fuel rod scanning applications.

Typical Side Well Crystal Models	
Model	Crystal Size
2RSW2	2" x 2"
3RSW3	3" x 3"

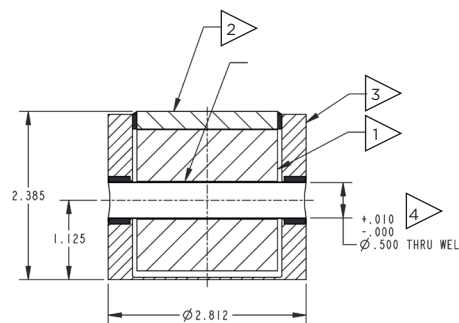

Model 2RSW2

Detectors can be built with a wide range of well sizes.

The drawing dimensions are nominal and subject to change. Call the factory for current values.

- 1 Scintillation Crystal
- 2 Optical Window
- 3 Aluminum Housing .020' [0.508] thick
- 4 Well Liner .010" [0.254] thick

SAINT-GOBAIN

Saint-Gobain Crystals

www.crystals.saint-gobain.com

Manufacturer reserves the right to alter specifications.
©2002-18 Saint-Gobain Ceramics & Plastics, Inc. All rights reserved.